

HTL 4017

TELEHANDLERS

Maximum lift capacity : **4 tons**
Placing height : **17.2 m**

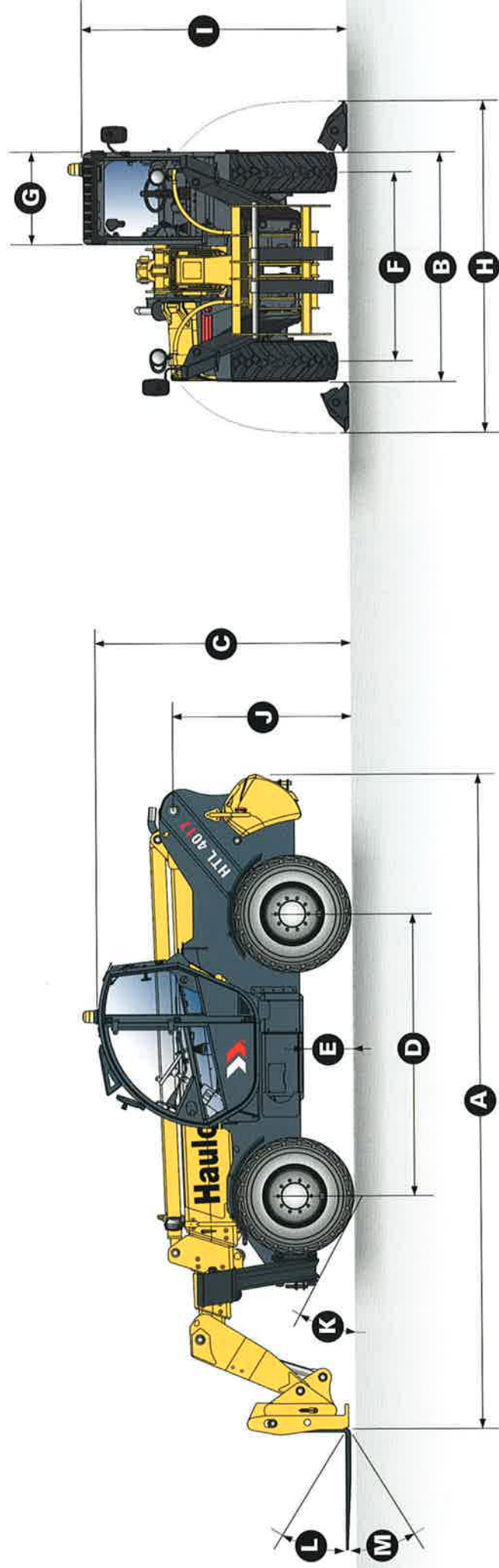

Technical data

Measurements

A	Length	6,76 m - 22 ft 2 in
B	Overall width	2,43 m - 8ft 0 in
C	Overall height	2,67 m - 8 ft 9 in
D	Wheelbase	2,9 m - 9 ft 6 in
E	Ground clearance	50 cm - 20 in
F	Track width	1,93 m - 6 ft 4 in
G	Cab width	0,96 m - 3 ft 2 in
H	Overall width - stabilizers down	3,34 m - 11 ft 0 in
I	Overall height - stabilizers down	2,7 m - 8 ft 10 in
J	Height to high boom pivot	1,75 m - 5 ft 9 in
K	Departure angle	29°

L	Upper rotation of forks	18°
M	Lower rotation of forks	104°
	Weight with forks	12100 kg - 26,681 lb
	Turning radius (inside wheels)	2,5 m - 8 ft 2 in
	Turning radius (outside wheels)	4,5 m - 14 ft 9 in
	Turning radius at fork	6,25 m - 20 ft 6 in
	Maximum distance between forks	104 cm - 41 in
	Tires	18-22,5 TMR4

Haulotte
GROUP

Experience in Innovation

H TL 4017

T E L E H A N D L E R S

Maximum lift capacity : **4 tons**
Placing height : **17.2 m**

Specifications



ENGINE

Model	Deutz TCD2012 L042VM
Type	Four-stroke, water-cooled
Capacity	4038 cm ³
Aspiration	Turbo
Puissance	74.9 kW / 102 hp at 2300 rpm (97/68EC)
Torque	420 Nm at 1600 rpm



HYDRAULICS

Precise and progressive movements thanks to the latest generation electrical proportional distributor.

Time and productivity gains are possible thanks to combined movements and high output from the torque regulating variable capacity pump.

Ergonomic and flexible joystick with 4 integrated proportional functions (lifting, excavation, telescopic and accessories functions).

Pump	Piston –variable capacity
Output	150 L/min
Pressure	260 b
Regulation	Load sensing with flow sharing (proportional and simultaneous movements)
Controls	Electro-hydraulic with 4-function joystick
Accessory socket output	62 L/min
Tank capacity	115 L



TYRES

Type | 18 – 22.5 TM R4 profile



TRANSMISSION

Unrivalled hydrostatic transmission flexibility.

Automatic speed variation from 0 to 30 km/h* without needing to change gears.

Variable approach speed thanks to inching / braking pedal (2-in-1 pedal), which is particularly useful when handling loads.

Automatic oscillation locking on rear supports (except during lateral manoeuvring) allowing a significant improvement in platform lateral stability when handling goods.

Type	Hydrostatic, with variable capacity pump and motor, permanent four-wheel drive
Gears	Electro-hydraulic, with 2/2 forward-reverse selector and neutral position
Speed in workin mode	0 – 8 km/h
Speed in travelling mode	0 – 30 km/h*
Slow approach	Yes – using inching pedal
Traction power	7100 daN
Maximum gradient	45%
Supports	With epicycloid reducer, differential locking on front axle
Oscillating axle	Yes – automatic in goods handling mode



FILLING CAPACITY

Fuel tank	132.5 L
Oil reservoir	115 L
Front axle	12.6 L
Rear axle	10.6 L
Transmission	0.5 L
Engine oil	10 L
Coolant	18 L



BRAKES

High-performance braking power thanks to multi-disk wet brakes. Electronically controlled, easy to use, safe parking brake (this is automatically activated when the engine is switched off).

Engine brake
Operating brakes
Parking brake

Hydrostatic
Multi-disk wet brakes, operated by the brake pedal
Multi-disk wet brakes, electrically operated



CABIN

The cabin conforms to ROPS (ISO 3471) / FOPS (ISO 3449) European safety standards. Independently opening two-section door, opening rear window with wiper, heating, ventilation and joystick with 4 proportional functions.



ELECTRICAL SYSTEM

Operating voltage	12 V
Battery	155 AH
Alternator	95 A
Starter	3 kW



STEERING

Steering type selector: two-wheel steering, four-wheel steering, "crab" steering

* according to local regulations

HTL 4017

TELEHANDLERS

Maximum lift capacity : 4 tons
Placing height : 17.2 m

Load charts

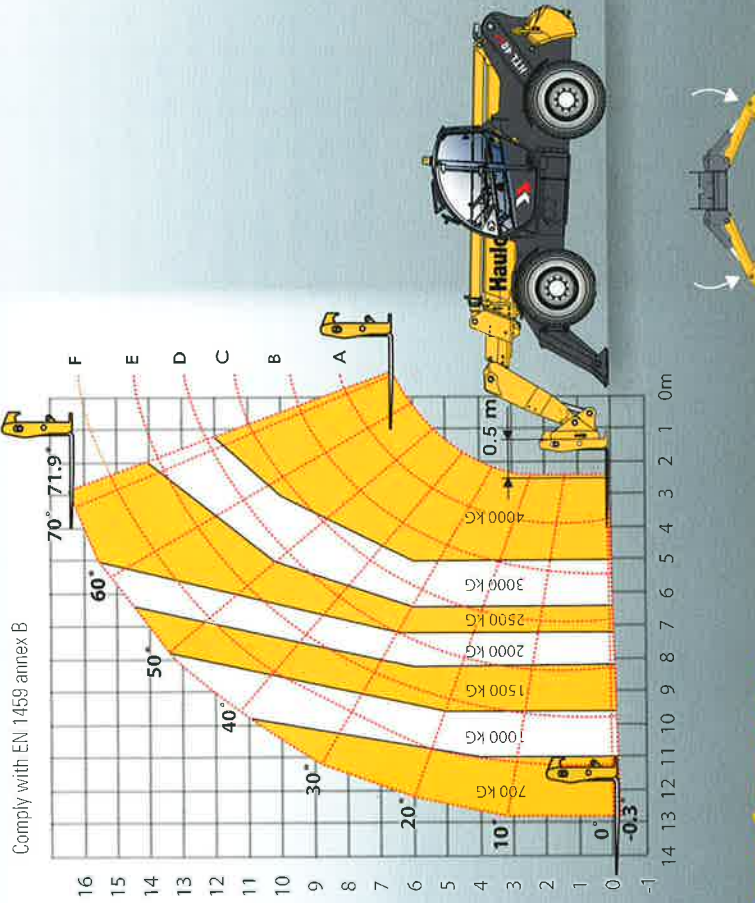

Lift performance Stabilizers down

Maximum lift capacity	4000 kg - 8,820 lb
Lift capacity to full height	2500 kg - 5,513 lb
Lift capacity at full reach	700 kg - 1,544 lb
Load over height	16,7 m - 54 ft 10 in
Reach at maximum lift height	2,4 m - 7 ft 10 in
Maximum forward reach	12,85 m - 42 ft 2 in

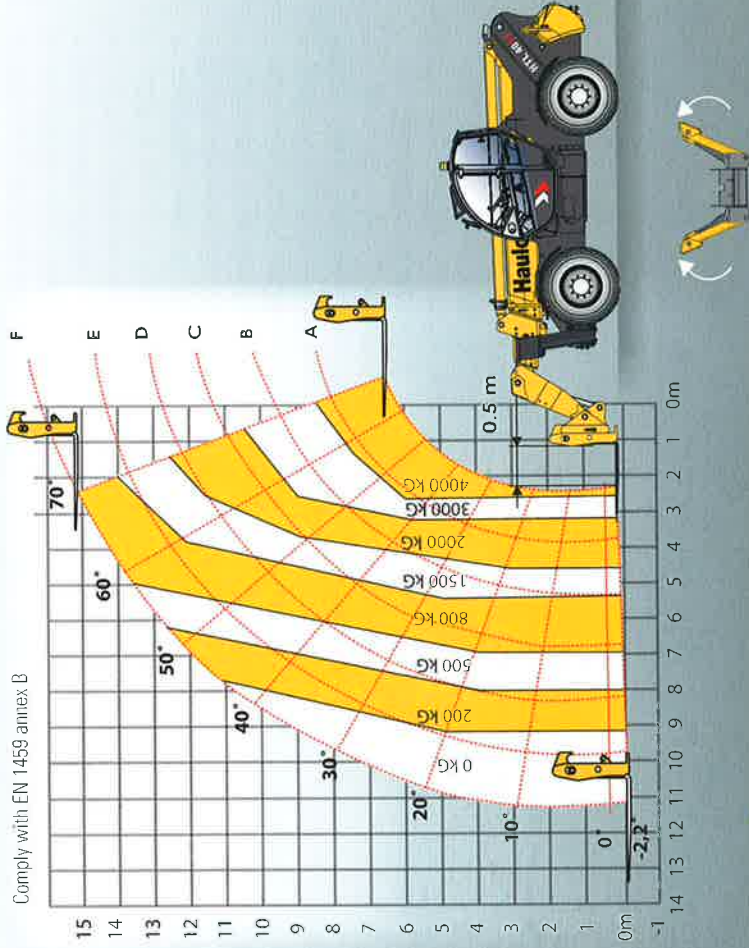

Lift performance Stabilizers up

Maximum lift capacity	4000 kg - 8,820 lb
Lift capacity to full height	800 kg - 1,764 lb
Lift capacity at full reach	0 kg - 0 lb
Load over height	15 m - 49 ft 3 in
Reach at maximum lift height	2,4 m - 7 ft 10 in
Maximum forward reach	11,4 m - 37 ft 5 in

HTL 4017

TELEHANDLERS

Maximum lift capacity : **4 tons**
Placing height : **17.2 m**

Standard equipment

- 4 litre capacity Deutz turbo engine
- 4-wheel drive and steering
- Dual-element air filter
- Fuel filter with water separator
- Handling system oil filter
- Equipment system oil filter
- Safety valves on hydraulic jacks
- Hydrostatic transmission with variable capacity pump and engine
- Load sensing equipment pump
- Flow sharing electrically controlled controls
- Proportional controls for mast / telescopic arm / excavation and accessories movements
- Possible combination of mast / telescopic arm / excavation and accessories movements
- Smooth approach movements thanks to inching system
- Accessories hydraulic system reaches top of arm
- Hydraulic axle locking,
- Stabiliser and tilt locking when arm is raised
- Long stabilisers with ground contact sensors
- Cut-off of dangerous movements when overloaded
- Anti-tilting cabin-mounted load controller with 5 LEDs: cut-off and audible alert with automatic reduction in rearward travel speed limit to ensure safety
- Tilt corrector: $\pm 10^\circ$
- ROPS/FOPS cabin with heating and ventilation
- Metal cabin roof protector
- Left/right exterior rear-view mirrors
- Adjustable seat (height and armrests) fitted with safety belt
- Adjustable steering column
- Four-function control joystick
- Hydraulically-assisted steering
- Visual hydraulic pressure indicator
- Display indicating that front wheels are aligned with rear wheels
- Arm angle indicator
- Electro-hydraulic gearbox with 2/2 forward-reverse selector and neutral position
- Travel mode configuration button
- Opening rear window with wiper
- Two-part door, opening midway, with latch in cabin
- Cabin door opens 180°
- Tinted, anti-glare windows
- Horn
- Tachograph
- Pre-installed radio and loud-speaker wiring

- Rotating light
- Mudguards
- Forks
- Manual apron attachment with 2 pegs
- Front and rear hooks
- Front and rear travelling lights
- 18 – 22.5 TM R4 6PR profile tyres

Optional equipment

- Cold environment kit
- Catalytic converter
- Biodegradable oil
- Cold environment oil
- Hot environment oil
- Air conditioning
- Working lights
- High comfort seat
- Vehicle radio
- Front left-hand exterior rear-view mirror
- Metal windscreen protector (FOPS)
- Floating levelling movement thanks to Rail Control system
- Rapid hydraulic connections with cabin-controlled locking
- 4-in-1 bucket: 1m3 or 0.75m3
- Bucket (no teeth): 1m3
- Bucket (with teeth): 0.75m3
- Side-mounted work tools apron
- Hooked bracket

For further options, consult the manufacturer.

The machine conforms to the following:

- EC directives
- TUV

Haulotte
GROUP

www.haulotte.com

Haulotte Group - La Péronnière - BP 9 - 42152 l'Horme - France • Tél : +33 (0)4 77 29 24 24 - Fax : +33 (0)4 77 29 43 95 - haulotte@haulotte.com